

ELECRAFT® K3

HIGH-PERFORMANCE 160 – 6 METER TRANSCEIVER

KAT3 100-WATT AUTOMATIC ANTENNA TUNER INSTALLATION INSTRUCTIONS

Rev B1, October 22, 2007

Copyright © 2007, Elecraft, Inc.

All Rights Reserved

Contents

Introduction.....	3
Customer Service and Support.....	3
Technical Assistance.....	3
Repair / Alignment Service.....	3
Preventing Electrostatic Discharge Damage	4
How ESD Damage Occurs.....	4
Preventing ESD Damage.....	4
Preparing for Installation.....	5
Tools Required.....	5
Parts Included.....	6
Installation Procedure	7

Introduction

The KAT3 option is an internally-mounted 100-watt automatic antenna tuner. Complete details for using the KAT3 are included in the KXV3 Owner's manual. This manual covers the installation of the KAT3 option in your K3 transceiver.

Only a few basic hand tools are needed (see page 5) to perform the installation. No soldering or wiring is required.

Customer Service and Support

Technical Assistance

You can send e-mail to support@elecraft.com and we will respond quickly - typically the same day Monday through Friday. Telephone assistance is available from 9 A.M. to 5 P.M. Pacific time (weekdays only) at 831-662-8345. Please use e-mail rather than calling when possible since this gives us a written record of the details of your problem and allows us to handle a larger number of requests each day.

Repair / Alignment Service (We want to make sure everyone succeeds!)

If necessary, you may return your Elecraft product to us for repair or alignment. (Note: We offer unlimited email and phone support to get your kit running, so please try that route first as we can usually help you find the problem quickly.)

IMPORTANT: You must contact Elecraft before mailing your product to obtain authorization for the return, what address to ship it to and current information on repair fees and turn around times. (Frequently we can determine the cause of your problem and save you the trouble of shipping it back to us.) Our repair location is different from our factory location in Aptos. We will give you the address to ship your kit to at the time of repair authorization. *Packages shipped to Aptos without authorization will incur an additional shipping charge for reshipment from Aptos to our repair depot.*

Elecraft 1-Year Limited Warranty

This warranty is effective as of the date of first consumer purchase. It covers both our kits and fully assembled products. For kits, before requesting warranty service, you should fully complete the assembly, carefully following all instructions in the manual.

What is covered: During the first year after date of purchase (or if shipped from factory, date product is shipped to customer), Elecraft will replace defective or missing parts free of charge (post-paid). We will also correct any malfunction to kits or assembled units caused by defective parts and materials. Purchaser pays inbound shipping to us for warranty repair, we pay shipping to return the repaired equipment to you by UPS ground service or equivalent to the continental USA and Canada. Alaska, Hawaii and outside U.S. and Canada actual return shipping cost paid by owner.

What is not covered: This warranty does not cover correction of kit assembly errors. It also does not cover misalignment; repair of damage caused by misuse, negligence, or builder modifications; or any performance malfunctions involving non-Elecraft accessory equipment. The use of acid-core solder, water-soluble flux solder, or any corrosive or conductive flux or solvent will void this warranty in its entirety. Also not covered is reimbursement for loss of use, inconvenience, customer assembly or alignment time, or cost of unauthorized service.

Limitation of incidental or consequential damages: This warranty does not extend to non-Elecraft equipment or components used in conjunction with our products. *Any such repair or replacement is the responsibility of the customer. Elecraft will not be liable for any special, indirect, incidental or consequential damages, including but not limited to any loss of business or profits.*

Preventing Electrostatic Discharge Damage

There is no climate or work location where the components of your K3 are safe from Electrostatic Discharge (ESD) unless you take specific steps to prevent such damage. Many of the components in your K3 can be damaged by static discharges of only a few volts: far too little for you to notice. It is those low-voltage but destructive discharges that easily happen anywhere and under virtually any environmental conditions.

ESD damage may not be apparent at first. The damaged components may not fail completely. Instead, the damage may result in below-normal performance for an extended period of time before you experience a total failure.

How ESD Damage Occurs

Whenever an object containing a static charge touches a circuit in your K3, current will rush into the circuit until the components reach the same voltage as the source of the static charge. If the voltage or current that passes through a component during that brief period exceeds its normal operating specifications, it may be damaged or destroyed.

Preventing ESD Damage

ESD damage cannot occur if there is no voltage difference between the components in your K3 and any object that touches them. That is how anti-static packaging works. Anti-static bags allow the static charge to flow over their surface, so that any part of the bag that touches the components inside are all at the same potential at all times. Anti-static foam keeps the leads of sensitive components at the same potential.

At your work bench, avoiding a dangerous voltage is achieved most easily by tying everything together and connecting them to a common mains safety ground. This includes your K3, individual boards or other sensitive components as well as everything they may touch at the work table.

Inexpensive static dissipating work mats are readily-available that will steadily and safely drain off any charges built up on parts or circuit boards placed on them. They are supplied with a lead that connects the mat to the common workbench ground. Also, metal cabinets on test equipment used on the bench should be tied together and connected to the common ground.

Most importantly, you must have a way of continuously draining off any static charges that occur on your body. Such charges are easy to create, even while sitting quietly at the work bench. Moving your feet on the floor, shifting position in your chair or even moving your arms so that clothing rubs against itself can produce destructive static charges. You can discharge yourself by touching an unpainted metal ground, but that will last only until you move in a way that produces a new static charge. The safest technique is to wear a grounded wrist strap with a series 1-megohm resistor that continuously drains off any charges. Such wrist straps are readily-available and inexpensive.

WARNING

DO NOT attach a ground directly to yourself without a current-limiting resistor as this poses a serious shock hazard. A wrist strap must include a 1-megohm resistor to limit the current flow. If you choose to touch an unpainted, metal ground to discharge yourself, do it only when you are not touching any live circuits with your other hand or any part of your body.

We strongly recommend you take the following anti-static precautions (listed in order of importance) to avoid trouble:

- Leave ESD-sensitive parts in their anti-static packaging until you install them. The packaging may be a special plastic bag or the component's leads may be inserted in conductive foam. Parts which are especially ESD-sensitive are identified in the parts list and in the assembly procedures.

- Wear a conductive wrist strap with a series 1-megohm resistor. If you do not have a wrist strap, touch a ground briefly before touching any sensitive parts to discharge your body. Do this frequently while you are working. You can collect a destructive static charge on your body just sitting at the work bench. **DO NOT attach a ground directly to yourself as this poses a serious shock hazard.**
- Use a grounded anti-static mat on your work bench.
- If you choose to use a soldering iron to work on your K3 for any reason, be sure your iron has an ESD-safe grounded tip tied to the same common ground used by your mat or wrist strap.

Preparing for Installation

Tools Required





1. #0 and #1 size Phillips screwdrivers. To avoid damaging screws and nuts, a power screwdriver is *not* recommended. Use the screwdriver that best fits the screw in each step.
2. Small pliers or a 1/4" nut driver.
3. Soft cloth or clean, soft static dissipating pad to lay cabinet panels on to avoid scratching.

The following tools are strongly recommended:

1. ESD wrist strap.
2. Static dissipating work pad.

Parts Included

The following parts should be included in your kit. Check to ensure you have them all. If any parts are damaged or missing, contact Elecraft for replacements (see *Customer Service and Support*, page 3).

ILLUSTRATION	DESCRIPTION	QTY.	ELECRAFT PART NO.
	KAT3 Printed Circuit Board Assembly ⚠ ESD Sensitive. Follow ESD safe handling procedures. Keep in ESD-safe bag until installed.	1	E850274
	SO239 Connector with cable	1	E850229
	Screw, Black, 4-40, 1/4" (6.4 mm)	2	
	Lockwasher, 4-40, inside tooth	2	
	Nut, 4-40	2	

Installation Procedure

- Disconnect power and all cables from your K3.
- Remove the nine screws to free the top cover as shown in Figure 1. After the cover is open, lift it gently to reach the speaker wire connector. Unplug the speaker then set the top cover aside in a safe place.

- 1 REMOVE 9 SCREWS HOLDING TOP COVER. 2 TO OPEN COVER, PRESS HERE TO TILT FRONT EDGE UP OR PLACE UNIT ON ITS SIDE FEET, THEN TIP FARTHER SO THE TOP COVER SWINGS OPEN.

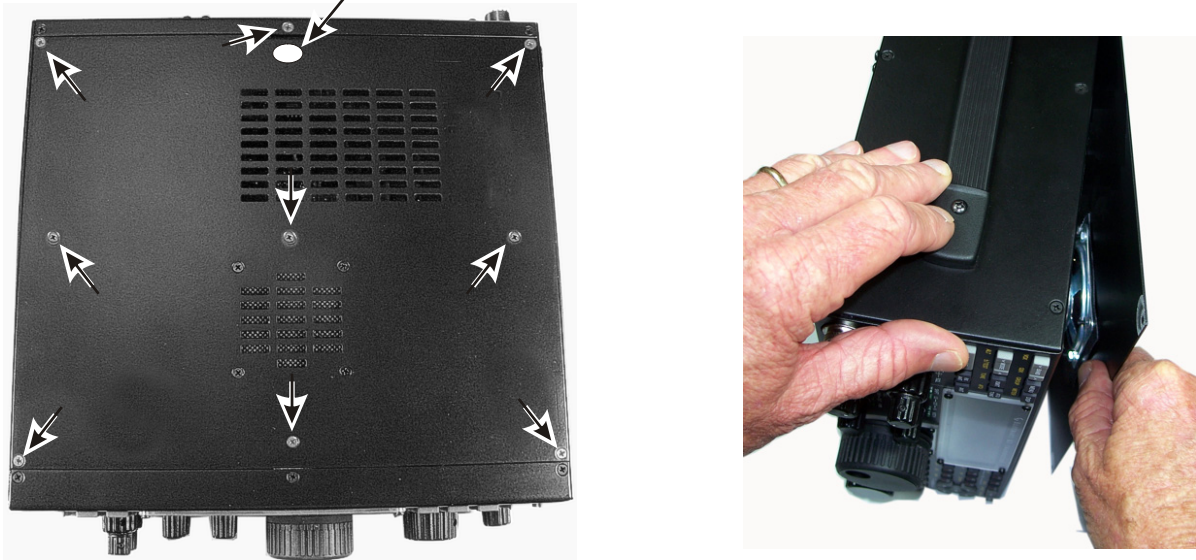

Figure 1. Removing K3 Top Cover.

⚠ CAUTION: Touch an unpainted metal ground or wear a grounded wrist strap before touching components or circuit boards inside the K3. See *Preventing ESD Damage* on page 4 for more information.

- Remove the hardware securing the heat sinks of U13 and U12 to the right side panel (see Figure 2). Be careful not to lose the lock washers inside the K3.

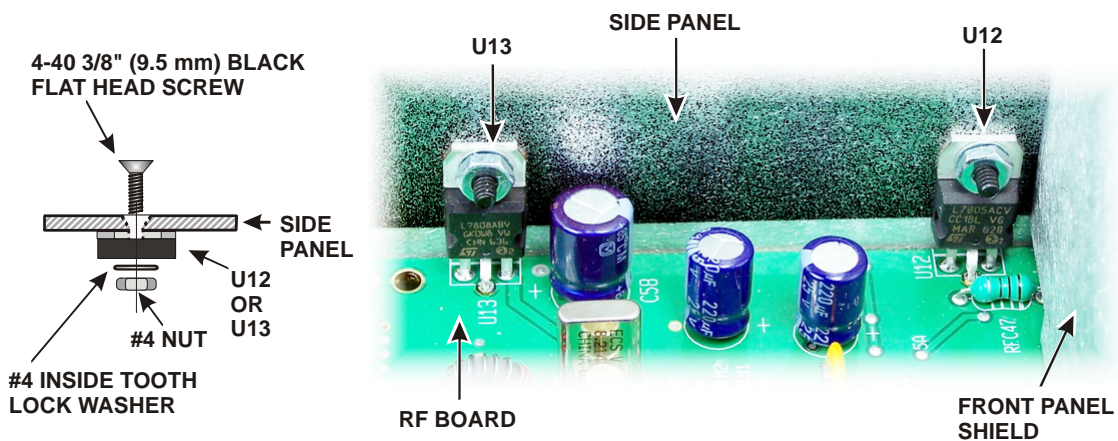

Figure 2. U13 and U12 Mounting Hardware.

☐ Remove the screw holding the KANT3 board to the standoff and the screw holding the 2D fastener to the rear panel near the SO239 antenna connector shown in Figure 3. Do not lose the lock washer inside the K3. It is easier to keep the hardware from falling inside if you set the K3 on its side feet and remove the screw and lock washer holding the KANT3 board first, then set it on its bottom feet and remove the flat head screw from the 2D fastener.

ESD SENSITIVE!
 WEAR A GROUNDED
 WRIST STRAP OR TOUCH
 AN UNPAINTED METAL GROUND
 BEFORE HANDLING THE RF BOARD.

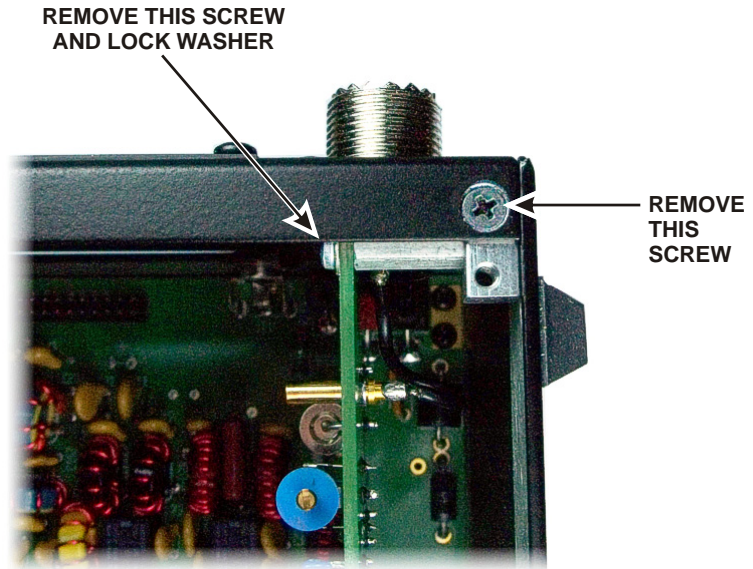

Figure 3. Removing Hardware Part 1.

☐ Remove the five screws shown in Figure 4 from the right side panel to release it. The side panel will lift off with the 2D fastener and standoff shown in Figure 3 attached.

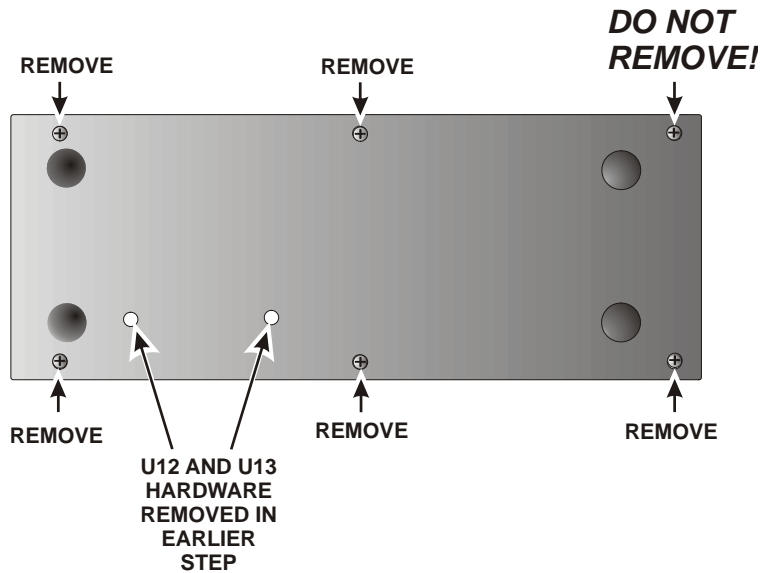

Figure 4. Removing Hardware, Part 2.

Unplug the antenna connection to the KANT3 board (see Figure 5) then unplug the KANT3 from the RF board and lift it out. Flex the back panel outward slightly as needed to clear the edge of the board. Holding the KANT3 board at the top corners, rock it back and forth as needed to release the connector.

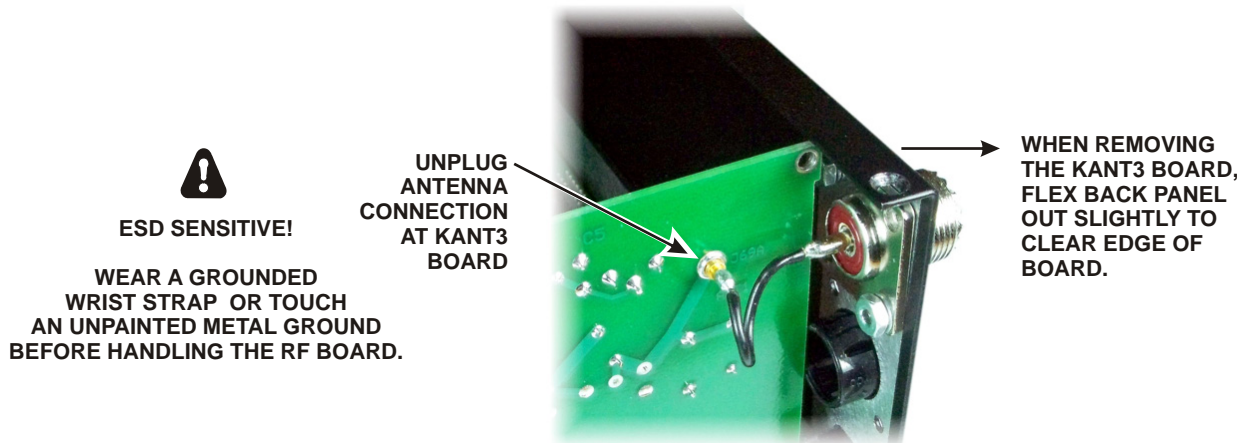

Figure 5. Removing KANT3 Board.

Remove the dummy plug from the ANT2 connector hole in the back panel. The plug is released by squeezing two tabs on opposite sides (see Figure 6).

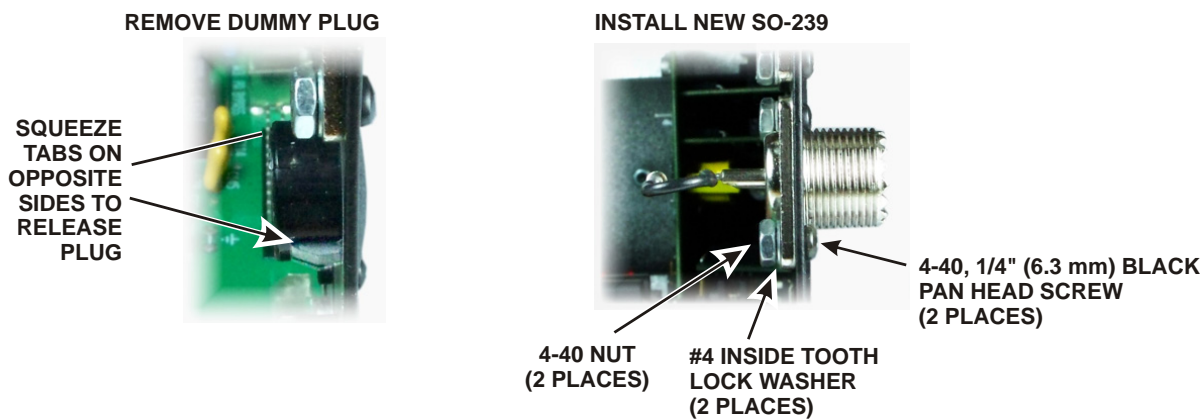

Figure 6. Installing ANT2 Connector.

Install the SO239 coaxial connector in the ANT2 space using the hardware shown in Figure 6.

⚠ As you install components and reassemble your K3, be sure all the screws are in place and secure, but do not over tighten them. Failure to tighten all screws may result in poor shielding of sensitive components, resulting in possible noise or birdies in the receiver as well as other difficult-to-trace problems.

Plug the KAT3 board into P70 on the RF board. This is the same plug that was used by the KANT3. **Wear a wrist strap or touch an unpainted metal ground before handling the boards.** Flex the back panel slightly as needed for the board to clear the lip at the top, just as you did when removing the KANT3 board.

Plug the connectors on the wires leading to the ANT1 and ANT2 jacks into the KAT3 board as shown in Figure 7. ANT1 goes to the connector nearest the rear panel, and ANT2 goes to the one farthest from the rear panel as shown. Support the top of the KAT3 board when plugging in these connectors. The fit may be very tight and the KAT3 board does not have any mechanical support at the top yet.

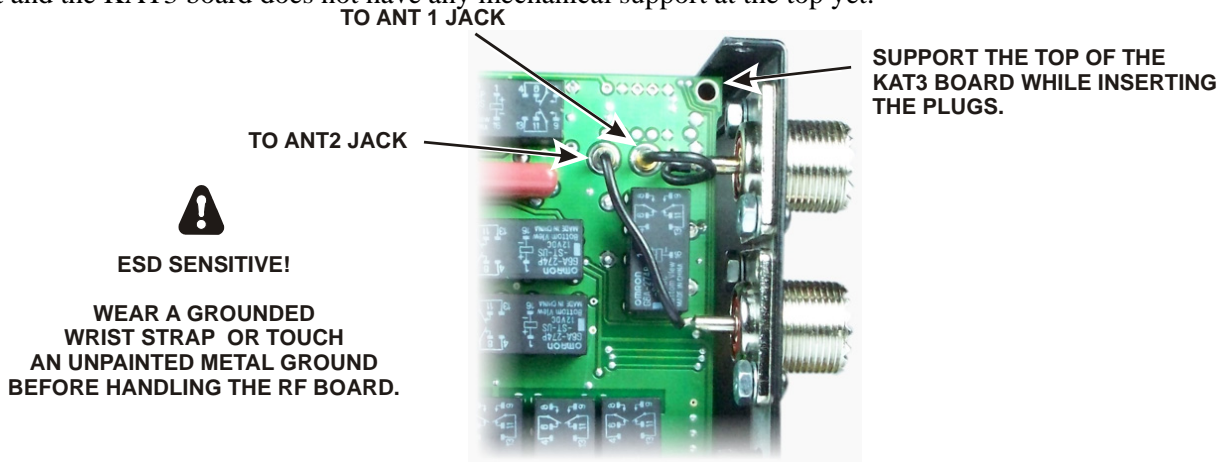

Figure 7. Installing the KAT3 Board.

- Replace the right side panel on the K3, installing screws shown in Figure 4 first. Use 4-40 3/16" (4.8 mm) screws.
- Replace the 4-40 1/4" (6.4 mm) zinc pan head screw and washer that holds the KAT3 board to the standoff as shown in Figure 3.
- Replace the 4-40, 3/16" (4.8 mm) black flat head screw that secures the back panel to the 2D fastener as shown in Figure 3.
- Replace the two 4-40 3/8" (9.6 mm) black flat head screws, lock washers and nuts to secure the heat sinks of U13 and U12 to the side panel as shown in Figure 2.
- Hold the top cover above the K3 and plug the speaker wire into P25 on the KIO3 board at the left rear of the K3 as shown in Figure 8.

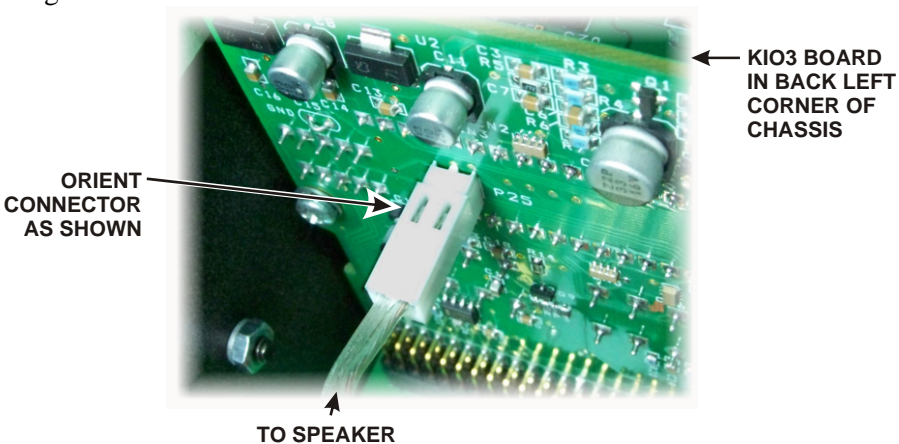

Figure 8. Connecting Speaker Cable.

Position the top cover on the K3. Note that the tab on the back center goes under the rear lip of the K3 rear panel. Secure the top cover with the nine 4-40 3/16" (4.8 mm) black flat head screws you removed earlier.

 REPLACE ALL THE SCREWS!

The K3's chassis has excellent rigidity despite its light weight. The screws that hold the top cover in place are an important part of the structural design. Be sure to replace all the screws and verify they are tight whenever you replace the cover or other panels

Reconnect power and antenna (or dummy load) to your K3 and turn it on. Enable your KAT3 ATU using the **CONFIG** commands as described in the Owner's Manual.

This completes the installation of the KAT3 interface in your K3.